

David  
Dolcini

**Lita**

David  
Dolcini

**Lita**

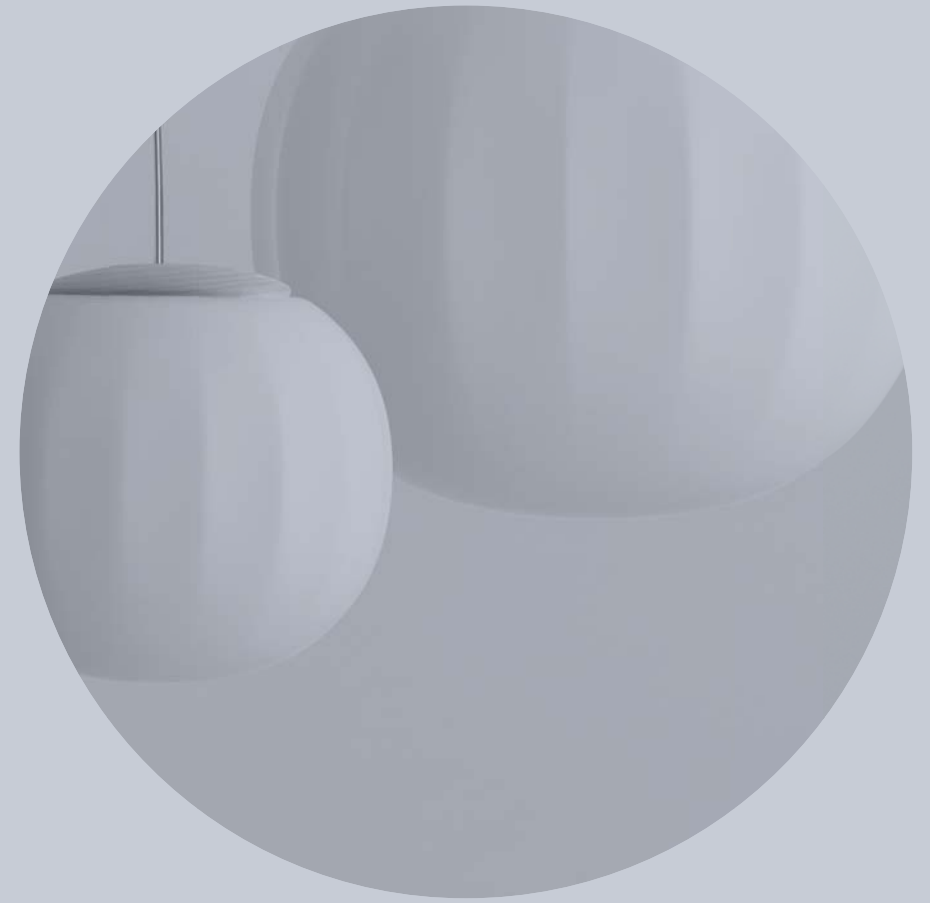



EN “I designed Lita in an attempt to incorporate certain elements that are fundamental for me inside the design process: history, the senses, harmony and balance. I wanted to create a timeless but very evocative classic, marked by clear ties to the past, an elegant, reassuring container of ancestral memories.”

IT “Ho disegnato Lita nel tentativo di racchiudere in essa alcuni elementi per me fondamentali all’interno del processo di progettazione: la storia, i sensi, l’armonia e l’equilibrio. Desideravo creare un classico senza tempo ma fortemente evocativo, caratterizzato da evidenti legami con il passato, che potesse essere un elegante e rassicurante contenitore di ricordi atavici.”

David Dolcini



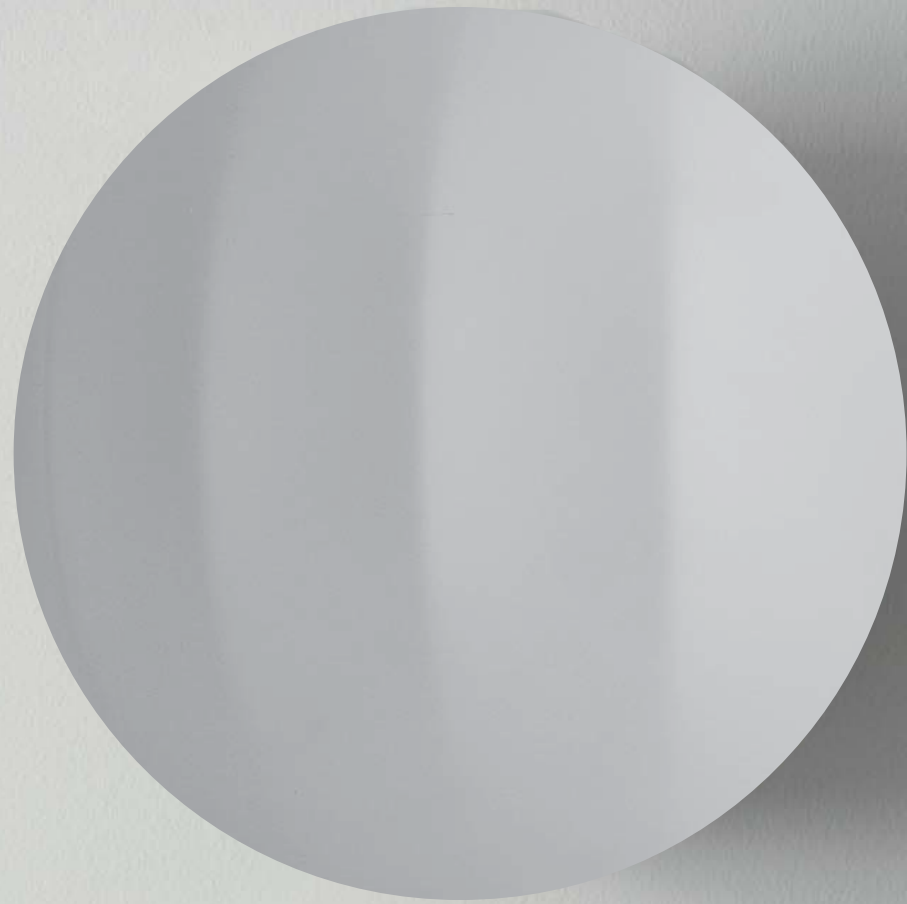

EN Lita by David Dolcini is an extremely versatile family of decorative lamps, the result of a delicate design process that mixes imagery, signs, geometric textures and natural materials.

The result is a collection with its own elegant simplicity, including table, floor, suspension and wall/ceiling solutions. The diffuser in opaline blown glass – whose surface is scanned by the repetition of slight vertical cusps that vanish at the extremities – is combined with a wooden structure, making Lita a product with a forceful material character. A timeless and evocative object that combines the crafts tradition with technical research, seductive in its way of matching visual and tactile sensations.

The diffuser, with its homogeneous light from traditional sources or retrofit LEDs, comes in four sizes: 14, 18, 30 and 42 cm in diameter. The structure comes in solid ash wood, or with a white painted aluminium finish.

IT Lita di David Dolcini è una famiglia di lampade decorative estremamente versatile, frutto di un delicato processo progettuale che mescola iconografie, segni, texture geometriche e materiali naturali.

Ne risulta una collezione dall'elegante semplicità che comprende soluzioni da tavolo, terra, sospensione, parete/plafone. Il diffusore in vetro soffiato opalino – la cui superficie è scandita dalla ripetizione di lievi cuspidi verticali che svaniscono ai poli – si sposa con la struttura in legno, rendendo Lita un prodotto dalla forte componente materica. Un oggetto atemporale ed evocativo che unisce tradizione artigianale e ricerca tecnica, incantando per la consonanza tra percezioni visive e tattili.

Il diffusore, illuminato omogeneamente da sorgenti tradizionali o retrofit LED, è disponibile in quattro dimensioni: diametro 14, 18, 30 e 42 cm. La struttura, oltre che in frassino massello, è disponibile con finitura in alluminio verniciato bianco.



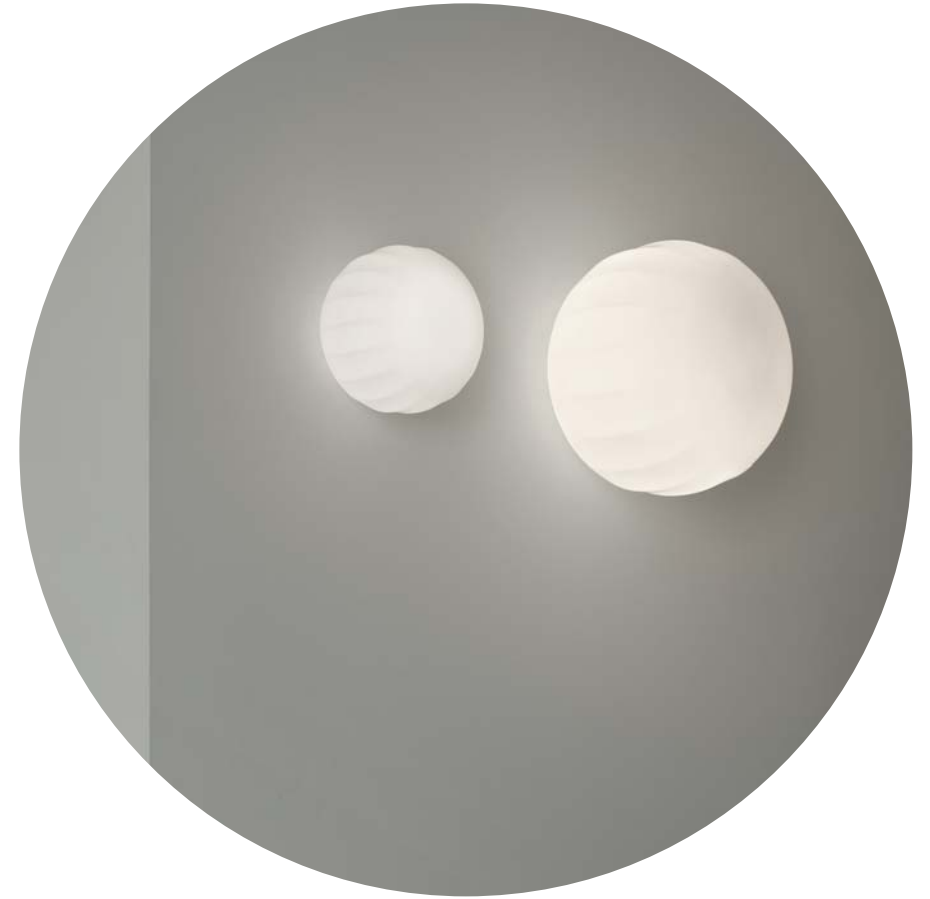





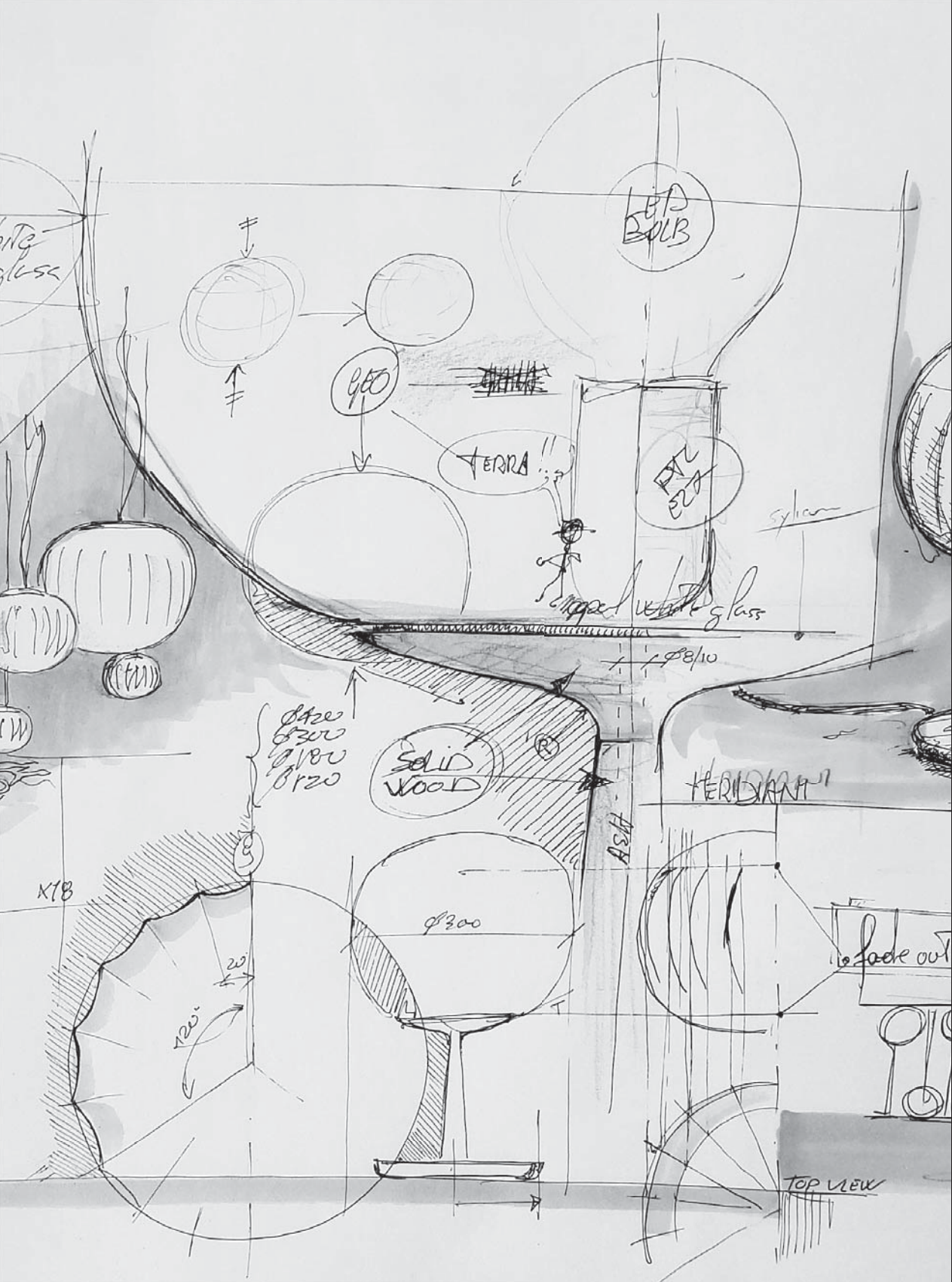

# Technical data

D92

Lita

D92 floor

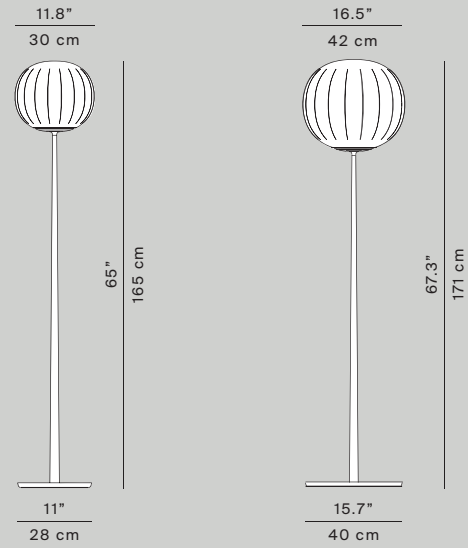

D92 table



D92 wall/ceiling

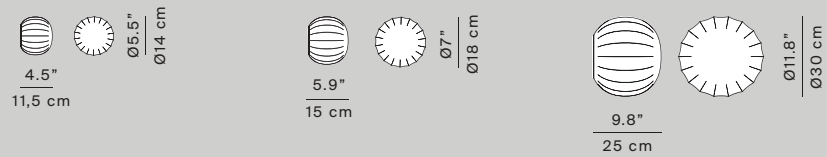

D92\* suspension

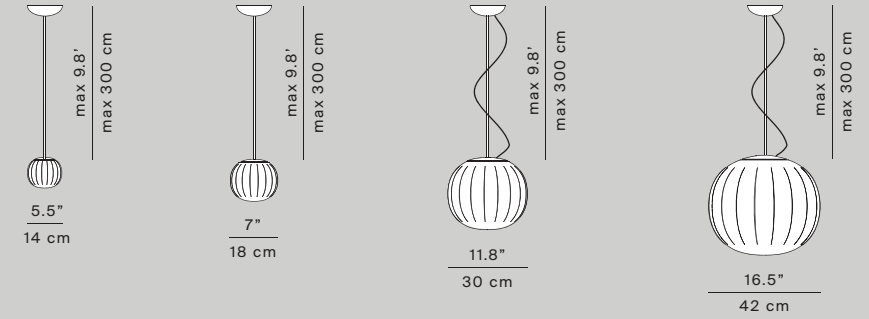



Materials

Solid ash wood or painted aluminium structure, blown glass diffuser

Lamp

LED G9 or LED E27 dimmable EEL: A++ / A+ / A

Structure finishes

-  Painted matt white
-  Ash wood

Certifications



Diffuser finishes

-  Satin opal



Photo: Mauro Corinti



**© Luceplan 2018**

Via E.T. Moneta 40  
20161 Milano  
T +39 02 66 242 1  
F +39 02 66 203 400  
info@luceplan.com  
www.luceplan.com

**Art direction**

Studio CCRZ  
Balerna

**Photography**

Studio 9010

**Styling**

Alessandra Monti  
(p. 5, 7, 8)

**Project**

**coordination**

Rosi Guadagno  
Alessandro Benini

**Printed by**

Alecom  
Bregnano

